

Installation and maintenance instructions for GRAF rainwater storage tank, Carat S series

2700 L 700 US-gallons	Order No. 372024
3750 L 1000 US-gallons	Order No. 372025
4800 L 1250 US-gallons	Order No. 372026
6500 L 1700 US-gallons	Order No. 372027



The points described in these instructions must be observed under all circumstances. All warranty rights are invalidated in the event of non-observance. Separate installation instructions are enclosed in the transportation packaging for all additional articles purchased from GRAF.

The tank must be checked for any damage prior to insertion into the trench under all circumstances.

Installation must be carried out by a specialist company.

Table of contents

1. General notes	14
1.1 Product features	14
1.2 Safety	14
1.3 Identification obligation	14
2. Installation conditions	15
3. Technical data	16
4. Tank structure	17
5. Installation and assembly	17
5.1 Tank assembly	18
5.2 Construction site	18
5.3 Trench	19
5.4 Insertion and filling	20
5.5 Routing connections	20
6. Assembling the tank dome and telescopic dome shaft	21
6.1 Fitting tank dome	21
6.2 Assembling the telescopic dome shaft	21
6.3 Telescopic dome shaft Maxi/Mini, pedestrian loading incl. cover	21
6. Assembling the tank dome and telescopic dome shaft	22
6.4 Telescopic dome shaft for vehicle loading with plastic/cast iron cover (class B125)	22
6.5 Universal telescopic dome shaft, accessible, without cover (D400)	22
6.6 Assembling the extension	22
7. Inspection and servicing	23

1. General notes

1.1 Product features

Congratulations on purchasing this quality product from GRAF.

The Carat S underground tank is made from 100% polypropylene. Polypropylene impresses with its chemical passivity, high durability and resistance to environmental influences. If the tank is filled with a medium other than rainwater, this must be approved by the manufacturer. The manufacturer assumes no liability for misuse of any kind if this has not been approved in advance.

1.2 Safety

The relevant accident prevention regulations must be observed during all work. Particularly when walking on the tanks, a 2nd person is required to secure the tank.

The relevant regulations and standards must additionally be taken into consideration during installation, assembly, servicing, repair, etc.

The system or individual parts of the system must be installed by qualified specialists.

During all work on the system or parts of the system, the entire system must always be rendered inoperable and secured to prevent unauthorised reactivation.

Except in the event of work carried out in the tank, the cover of the tank must always be kept sealed, as this otherwise constitutes a maximum risk of accident. Only original GRAF covers or covers approved in writing by GRAF must be used.

GRAF offers an extensive range of accessories, all of which are designed to match each other and which can be extended to form complete systems. The use of accessories that have not been approved by GRAF results in the exclusion of the warranty/guarantee.

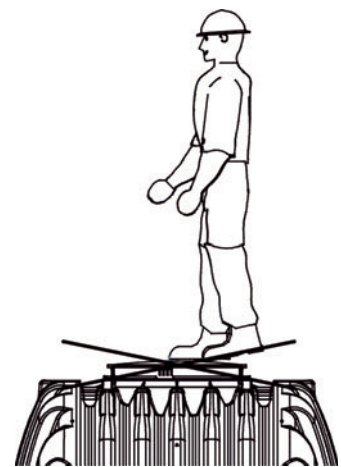

1.3 Identification obligation

All service water pipes and outlets must be identified in writing with the words **"Not drinking water"** or in the form of images in order to avoid inadvertent connection with the drinking water mains even after a number of years. Mix-ups, e.g. by children, may still occur even in the case of correct identification. All service water extraction points must therefore be installed with valves with **child-proof locks**.

2. Installation conditions

Coverage heights with telescopic dome shaft in green areas.

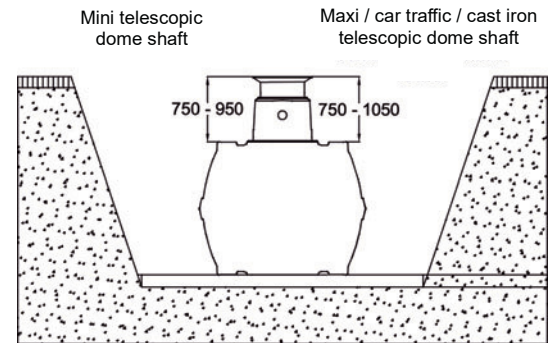

Maximum coverage heights with extensions and telescopic dome shaft.

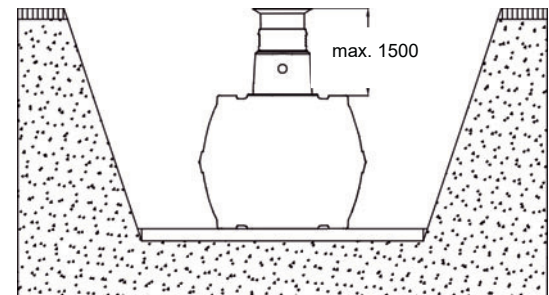

Cover heights with telescopic dome shaft car traffic / telescopic dome shaft cast iron in areas with car traffic (load up to 3.5 tonnes).

Without groundwater and stratum water.

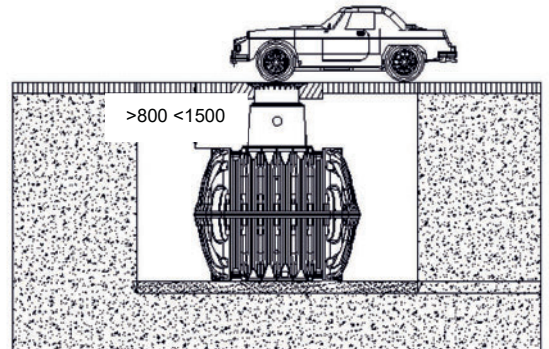

Coverage heights with Begu telescopic dome shaft (with cover class D – to be provided at construction site) in areas used by trucks with a max. weight of 12 to.

Without groundwater or stratum water.

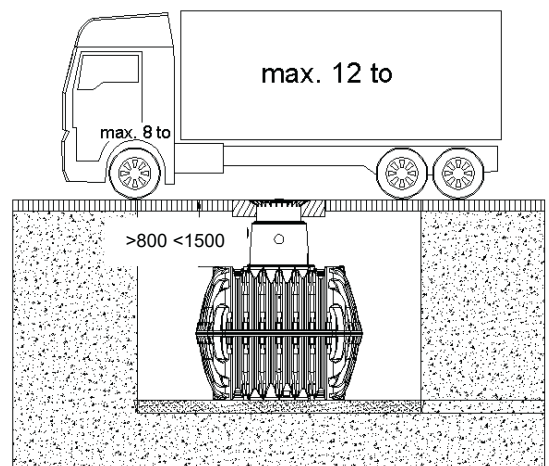

Coverage heights on installation in groundwater – the hatched area specifies the permissible immersion depth for the tanks.

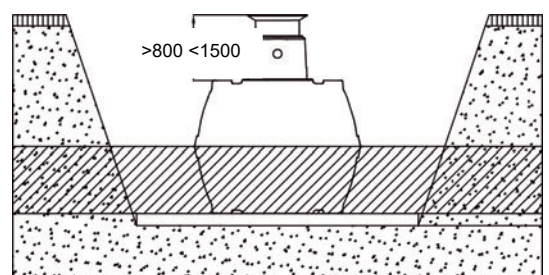

3. Technical data

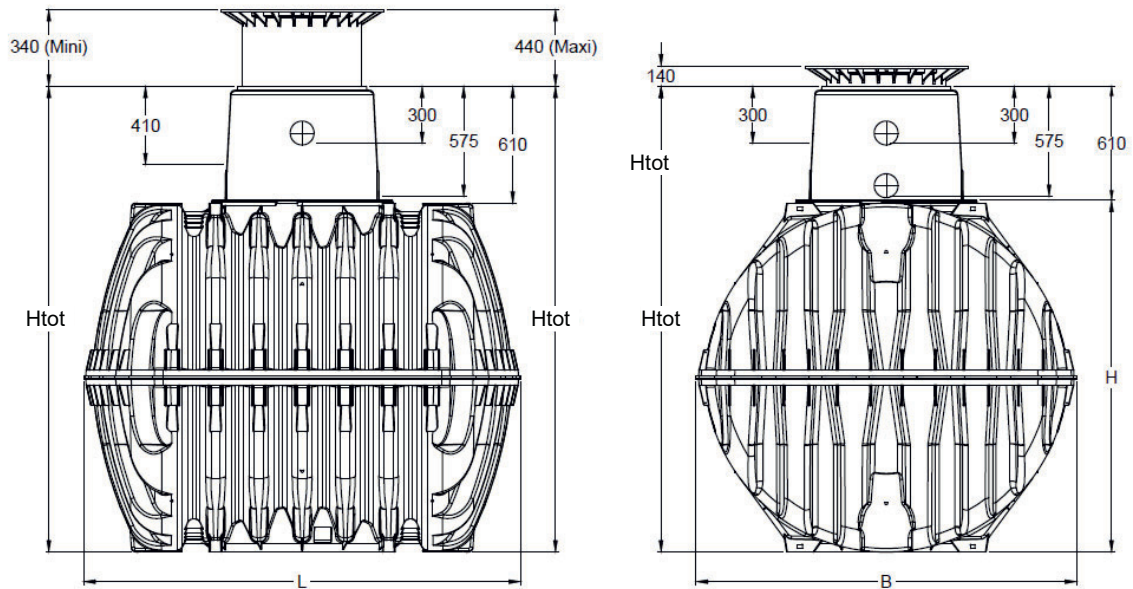

Tank	2700 litres 700 US-gallons	3750 litres 1000 US-gallons	4800 litres 1250 US-gallons	6500 litres 1700 US-gallons
Art. No.	372024	372025	372026	372027
Weight	120 kg	150 kg	185 kg	220 kg
L	2080 mm	2280 mm	2280 mm	2390 mm
W	1565 mm	1755 mm	1985 mm	2190 mm
H	1400 mm	1590 mm	1820 mm	2100 mm
Htot*	2010 mm	2200 mm	2430 mm	2710 mm

* Htot = total height

4. Tank structure

- ① Cover
- ② Telescopic dome shaft (can be inclined by 5°)
- ③ Profile seal
- ④ Tank dome (can be rotated by 360°)
- ⑤ Tank – Tank dome seal
- ⑥ Upper half shell / Carat S underground tank
- ⑦ Centring pins
- ⑧ Profile seal
- ⑨ Quick connection
- ⑩ lower half shell / Carat S underground tank

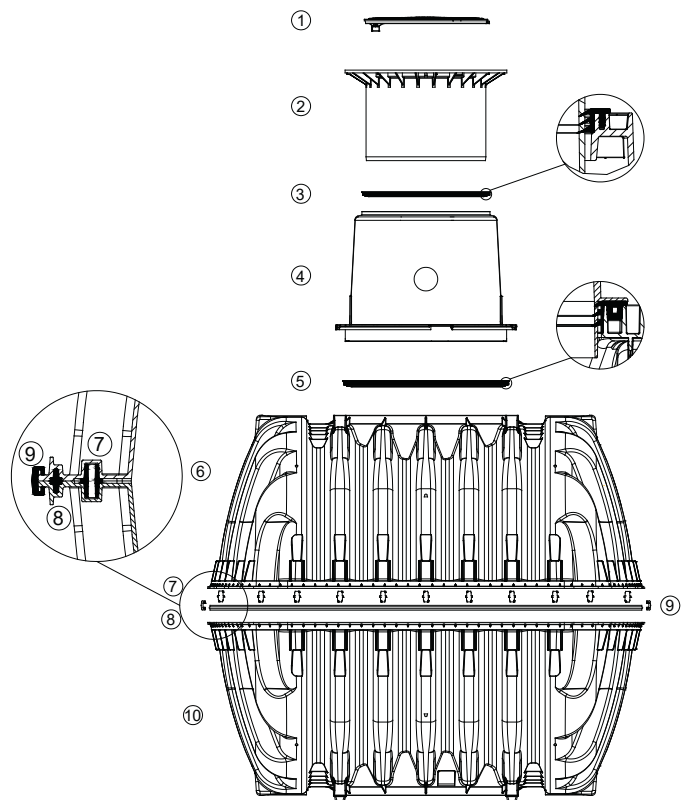

5. Installation and assembly

- ① Subsoil
- ⑤ Covering layer
- ② Telescopic dome shaft
- ⑥ Carat underground tank
- ③ Compacted foundation
- ⑦ Concrete layer for surfaces used by passenger cars
- ④ Surrounding (round-grained gravel, max. grain size 8/16)

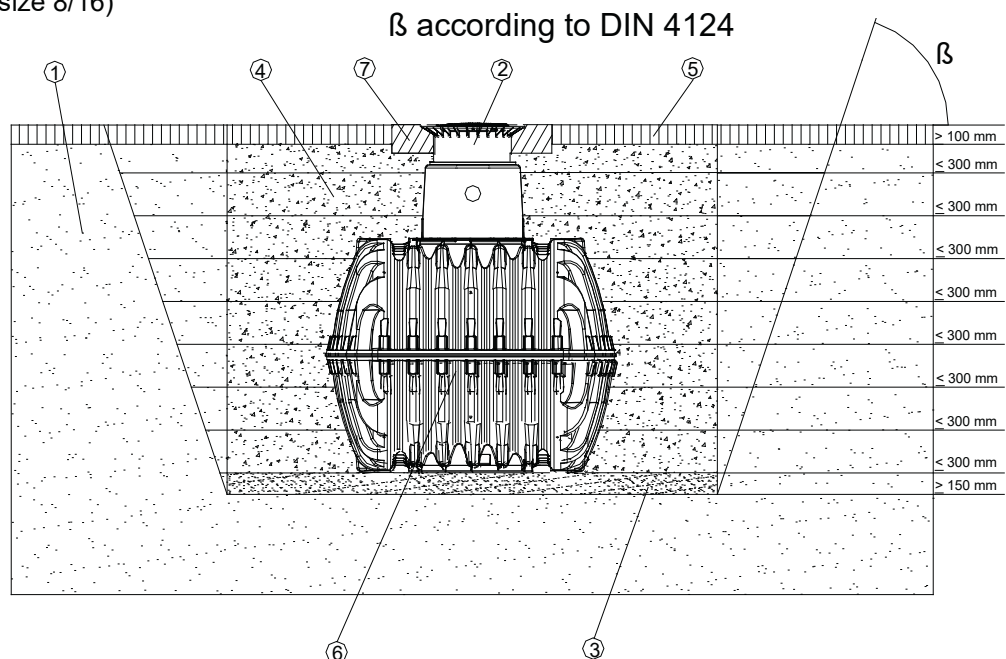

5. Installation and assembly

5.1 Tank assembly

First insert the circumferential profile seal ② into the sealing groove in the lower half shell ①. Lightly coat the seal with the enclosed soft soap.

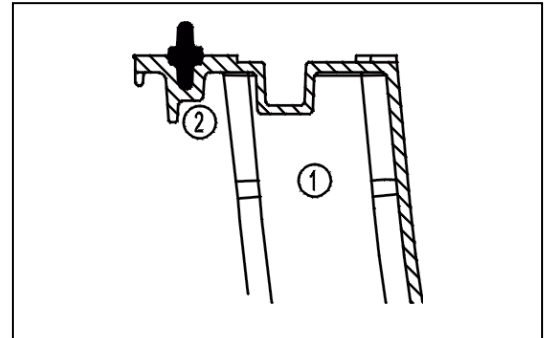

Then insert the centring pins ③ into the intended mountings around the circumference.

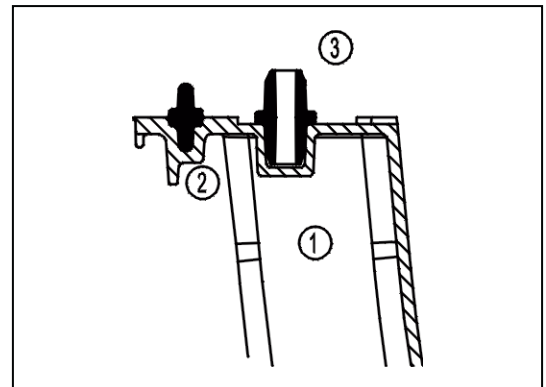

The upper half shell ④ is now positioned onto the lower half shell ① and the quick connectors ⑤ are installed. To do this, each 2nd quick connector is pre-adjusted in the 1st step and is secured with a hammer and a wooden support. The quick connectors engage in their end position. The remaining quick connectors are then installed.

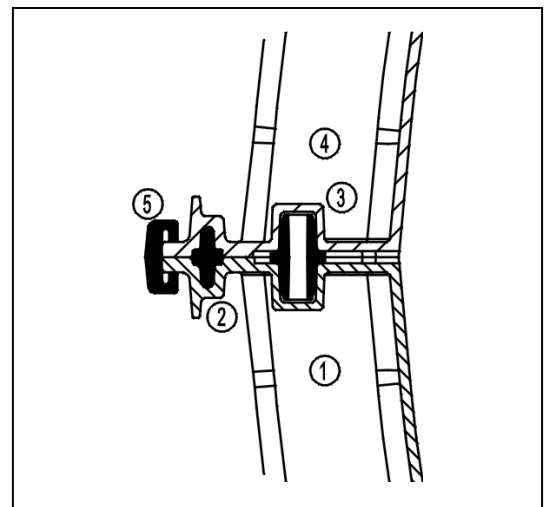

Attention: When positioning the upper half shell, it must be ensured, under all circumstances, that the seal does not slip out of the groove.

5.2 Construction site

Under all circumstances, the following points must be clarified prior to installation:

- The structural suitability of the ground according to DIN 18196
- Maximum groundwater levels which occur and drainage capability of the subsoil
- Types of load which occur, e.g. traffic loads

An expert ground report should be requested from the local planning authority to determine the physical characteristics of the subsoil.

5. Installation and assembly

5.3 Trench

To ensure that sufficient space is available for working, the base area of the trench must exceed the dimensions of the tank by 500 mm on each side; the distance from solid constructions must be at least 1000 mm.

The trench embankment must be designed so that slippage or collapse of the embankment wall is not to be anticipated. The construction site must be horizontal and plane and must guarantee sufficient load-bearing capacity.

The depth of the trench must be dimensioned so that the max. earth coverage (see point 2 – installation conditions) above the tank is not exceeded. To use the system throughout the entire year, it is necessary to install the tank and those parts of the system which conduct water in the frost-free area. The frost-free depth is usually approx. 600 mm – 800 mm; precise information in this regard can be obtained from the responsible authority.

A layer of compacted, round-grain gravel (grain size 8/16, thickness approx. 150 - 200 mm) is applied as the foundation.

5.3.1 Slope, embankment, etc.

On installation of the tank in the immediate vicinity (< 5 m) of a slope, earthen mound or slope, a statically calculated supporting wall must be erected to absorb the soil pressure. The wall must exceed the dimensions of the tank by at least 500 mm in all directions and must be located at least 1000 mm away from the tank.

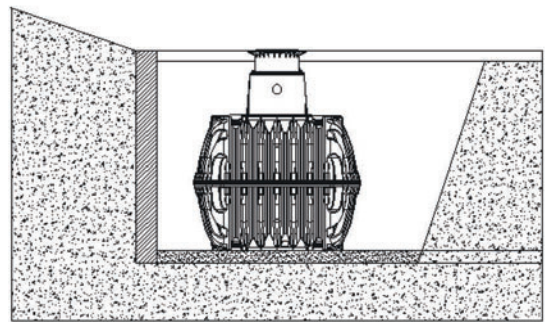

5.3.2 Groundwater and cohesive (water-impermeable) soils (e.g. clay soil)

If it is anticipated that the tanks will be immersed deeper into the groundwater than is shown in the adjacent figure, sufficient dissipation must be ensured. (See table for max. immersion depth).

Dissipation of the drainage water (e.g. via an annular drainage system) is recommended in the case of cohesive, water-impermeable soils.

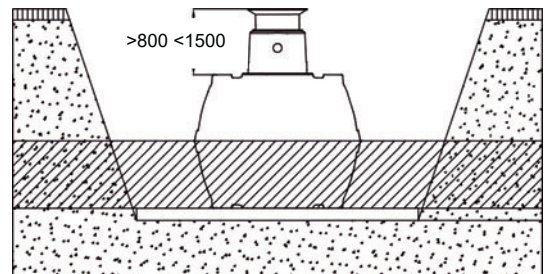

Tank size	2700 L 700 US-gallons	3750 L 1000 US-gallons	4800 L 1250 US-gallons	6500 L 1700 US-gallons
Immersion depth	700 mm	795 mm	910 mm	1050 mm

5.3.3 Installation adjacent to surfaces used by vehicles

If the underground tanks are installed adjacent to surfaces which are used by vehicles heavier than passenger cars, the minimum distance away from these surfaces is at least the depth of the trench.

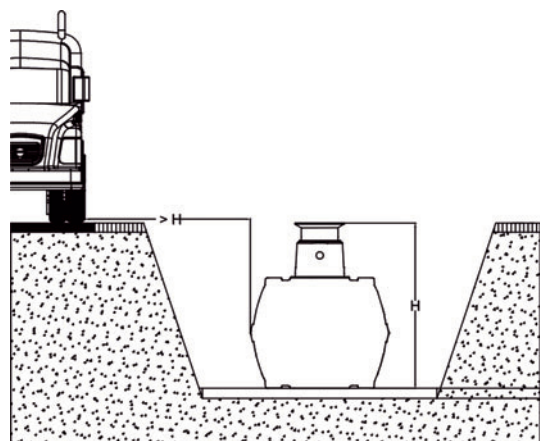

5. Installation and assembly

5.3.4 Connection of several tanks

Two or more tanks are connected via the assembly surfaces by means of GRAF special seals and basic pipes (to be provided at construction site).

The apertures must be drilled to the corresponding size using only the GRAF special crown bit. It must be ensured that the distance between the tanks is at least 600 mm. The pipes must project at least 200 mm into the tanks.

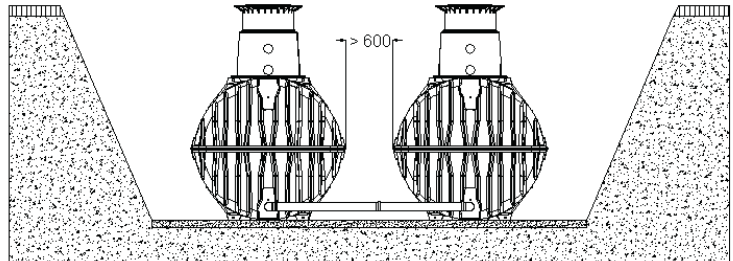

5.4 Insertion and filling

The tanks must be inserted, impact-free, into the prepared trench using suitable equipment. The tank is filled with 1/3 water before filling in the tank surrounding.

Afterwards the surrounding (roundgrain gravel, max. grain size 8/16) is then filled in layers of max. 30 cm steps and is compacted. The individual layers must be well-compacted (manual tamper). Damage to the tank must be avoided during compaction. Mechanical compaction machines must not be used under any circumstances. The surrounding must be at least 500 mm wide.

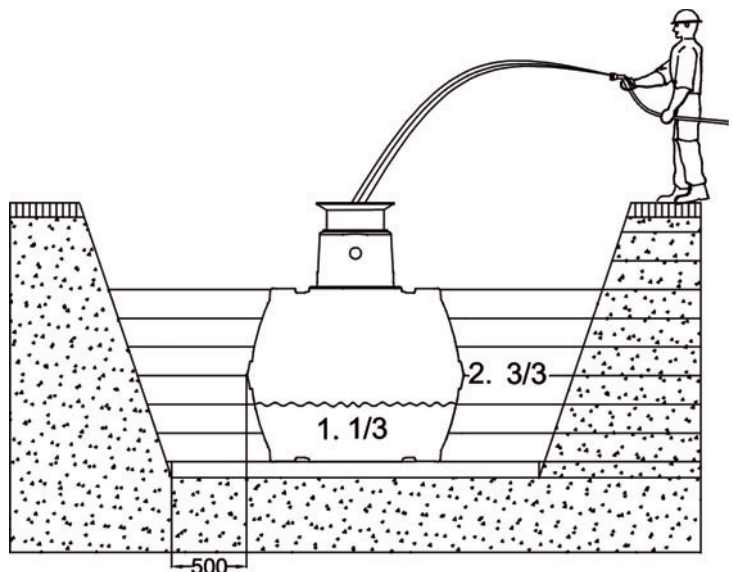

5.5 Routing connections

All feed and overflow pipes must be routed with a decline of at least 1% in the direction of flow (possible, subsequent settling must be taken into consideration in this case). If the tank overflow is connected to a public sewer, this must be protected against reflux by means of a lifting station (mixed sewer) or reflux seal (pure rainwater sewer) according to DIN 1986.

All suction, pressure and control lines must be routed in an empty pipe, which must be routed as straight as possible, without bending, to the tank with a decline. Necessary bends must be formed using 30° moulded sections.

Important: The empty pipe must be connected to an aperture **above** the max. water level.

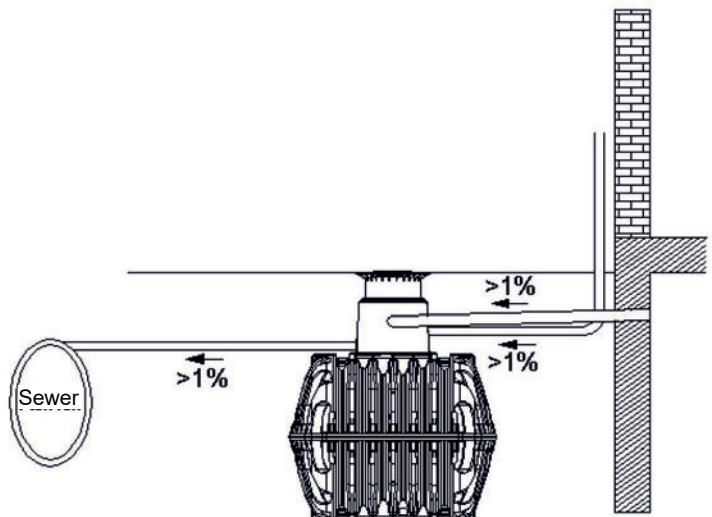

6. Assembling the tank dome and telescopic dome shaft

6.1 Fitting tank dome

Before the actual installation, the supplied seal is inserted between the tank and the tank dome in the sealing groove of the tank neck "B", then the tank dome is aligned with the pipework and pushed into the tank neck as far as it will go. It is essential to ensure that the upper seal "A" is correctly in place.

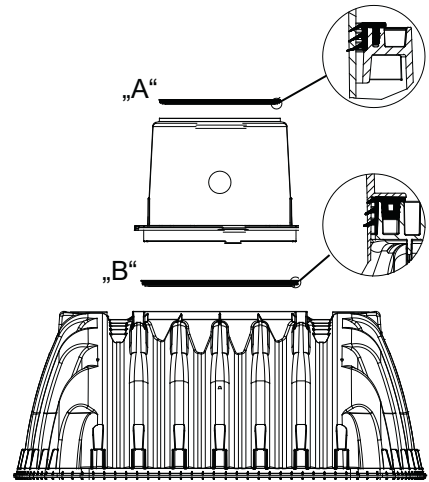
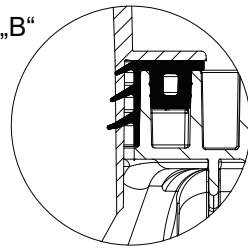
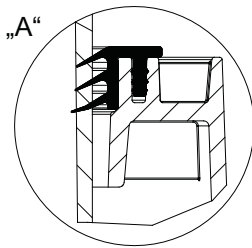

6.2 Assembling the telescopic dome shaft

The telescopic dome shaft enables the tank to be variably adjusted to the given terrain surface. For assembly, the profile seal (EPDM material) of the tank dome is generously rubbed with soft soap (do not use lubricants based on mineral oil, as these attack the seal). The telescope is then also greased, inserted and levelled to the ground surface.

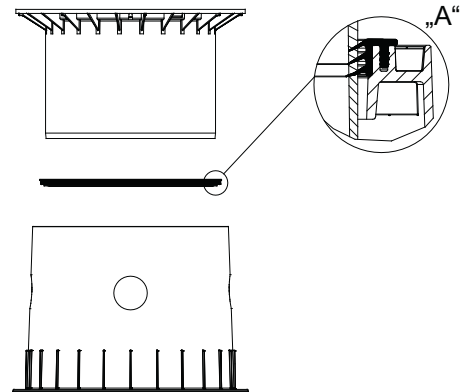
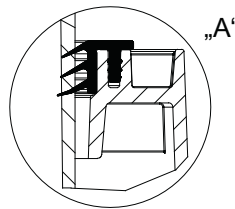

6.3 Telescopic dome shaft Maxi/Mini, pedestrian loading incl. cover

To prevent loads from being transferred to the tank, the telescope ① is filled in layers (< 300 mm) with round grain gravel ② (max. grain size 8/16) and compacted evenly. Damage to the container tank dome ③ or telescope must be avoided. Then place the manhole cover in position, screw the cover lock shut with a hexagon spanner and tighten it so that it cannot be opened without tools.

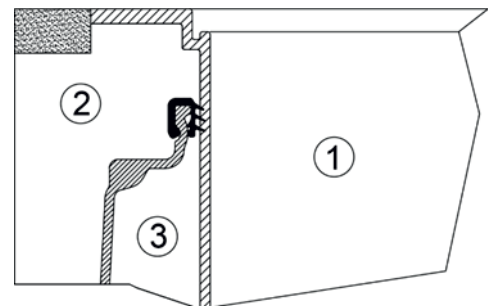

6. Assembling the tank dome and telescopic dome shaft

6.4 Telescopic dome shaft for vehicle loading with plastic/cast iron cover (class B125)

If the container is installed under car traffic areas, the telescopic ① must be underlaid with concrete ④ (concrete quality C20/25) in the collar area. The concrete layer to be filled must be at least 300 mm wide and approx. 200 mm high all round.

Only for telescopic manhole for cars: Close the manhole cover with a hexagon spanner and tighten it so that it cannot be opened without tools.

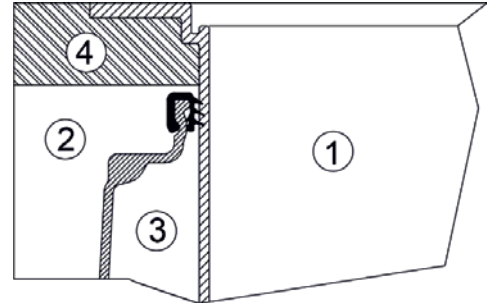

6.5 Universal telescopic dome shaft, accessible, without cover (D400)

For installation under lorry traffic areas, the telescope ① is shimmed as described in point 6.4 above. The cast frame ⑤ to be provided by the customer or the concrete rings ⑥ to be provided by the customer are then installed to distribute the load on the cover. The cast frame must have a bearing surface of approx. 1 m² so that the load forces cannot be transferred to the manhole casing ③ under any circumstances.

(cover to be provided on site)

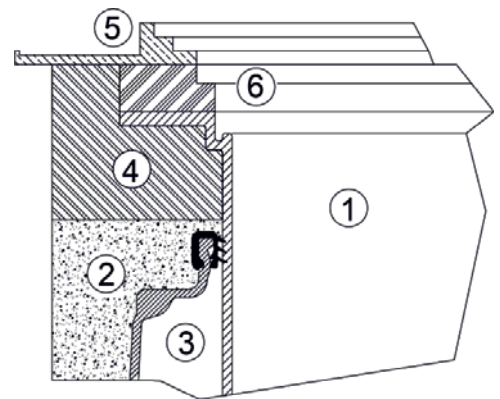

6.6 Assembling the extension

For larger coverage heights an extension is needed. To insert the extension into the tank dome, soft soap is needed. Into the highest groove of the extension the profile seal is inserted and greased generously. Afterwards push the telescopic dome shaft into the extension and adapt it to the planned area surface.

max. earth-cover 1500 mm

(in each case in connection with the Maxi telescopic dome shaft)

① Telescopic dome shaft (can be inclined by 5°)

② Extension

③ Tank dome (can be rotated by 360°)

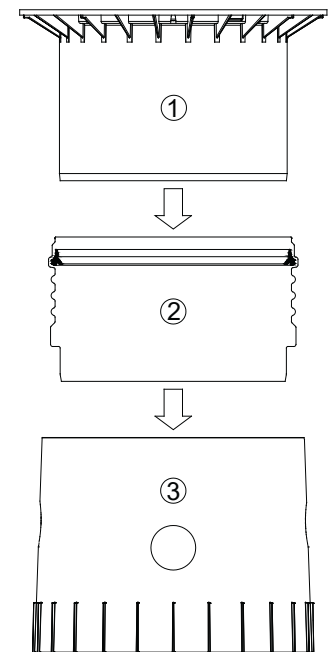

7. Inspection and servicing

The entire system must be checked for leaks, cleanliness and stability at least every three months.

The entire system should be serviced at intervals of approx. 5 years. In this case, all parts of the system must be cleaned and their function checked. Servicing should be carried out as follows:

- Drain the tank completely
- Clean surfaces and internal parts with water
- Remove all dirt from the tank
- Check that all internal parts are firmly seated.