

## Instructions for installation and maintenance of Graf Herkules tank 1600 litres

**GRAF – Herkules tank  
for overground and  
underground installation**

**Order No.: 320001**

**These instructions also apply  
to:**

**HERKULES Collector Pit  
1600 L green**

**Order No.:100001**



The points described in these instructions must be observed under all circumstances. All warranty rights are invalidated in the event of non-observance. Separate installation instructions are enclosed in the transportation packaging for all additional articles purchased from GRAF.

Missing instructions must be requested from us immediately.

The tank must be checked for any damage prior to insertion into the trench under all circumstances.

Missing instructions can be downloaded on [www.graf.info](http://www.graf.info) or can be requested from GRAF.

### Table of contents

<b>1. GENERAL NOTES</b>	<b>10</b>
1.1 Safety	10
1.2 Identification obligation	10
<b>2. INSTALLATION CONDITIONS</b>	<b>10</b>
2.1 Overground assembly	10
2.2 Underground installation	10
<b>3. TECHNICAL DATA</b>	<b>11</b>
<b>4. TRANSPORT AND STORAGE</b>	<b>12</b>
4.1 Transport	12
4.2 Storage	12
<b>5. INSTALLATION TANK</b>	<b>12</b>
5.1 Test installation	12
5.2 Installation tank	12
<b>6. OVERGROUND AND UNDERGROUND INSTALLATION</b>	<b>13</b>
6.1 Overground installation	13
6.2 Underground installation	13
<b>7. INSTALLATION TANK HEAD DN 200</b>	<b>15</b>
<b>8. SERVICE AND MAINTENANCE</b>	<b>15</b>

## 1. General notes

### 1.1 Safety

The relevant accident prevention regulations according to BGV C22 have to be observed when conducting any works. Especially when inspecting tanks a second person is required for safety reasons.

Furthermore, the relevant regulations and standards have to be observed during installation, assembly, maintenance, repair, etc. You will find information about this in the related sections of these instructions.

During all works on the system respectively on system components the overall system has to be decommissioned and secured against unintentional restart at all times.

The tank cover has to be closed at all times, except when conducting works on the tank, otherwise there is a very high risk of accident. Only original GRAF covers or covers approved by the company GRAF in writing are to be used.

The company GRAF offers a comprehensive portfolio of accessories that are aligned with each other and can be developed into complete systems. The use of accessories that have not been approved by GRAF results in the exclusion of the warranty/guarantee.

### 1.2 Identification obligation

All lines and tapping points of process water have to be labelled with the words “**No drinking water**” in writing or visually (DIN 1988 part 2, section 3.3.2.) in order to avoid an accidental connection to the drinking water network even after years. Even when there are correct labels, irritations are possible, e.g. through children. That is why all tapping points of process water have to be installed with **child-proof** valves.

## 2. Installation conditions

### 2.1 Overground assembly

- The tanks have to be installed on firm and level ground without sharp stones and without incline
- Please observe the weight of the filled tank during assembly (1,650 kg)
- In case of risk of frost, the tanks have to be emptied completely
- When installing the tanks in closed rooms there has to be a floor drain
- Children need supervision when lingering near the tanks
- The tank must not be pressurised (water column)

### 2.2 Underground installation

- By using the supporting tube (Order No. 322014) the tank may be installed under ground (max. height above ground 1000 mm)
- The tank head (Order No. 322026) has to be installed for possible revision works
- In case of ground water and hillside situation special installation provision have to be observed
- The tanks must only be installed in non-accessible green areas
- Along with the earth load no additional loads must affect the tank in any case, the distance to the accessible areas has to be at least 2.6 m
- The tank must not be pressurised (water column)

### 3. Technical data

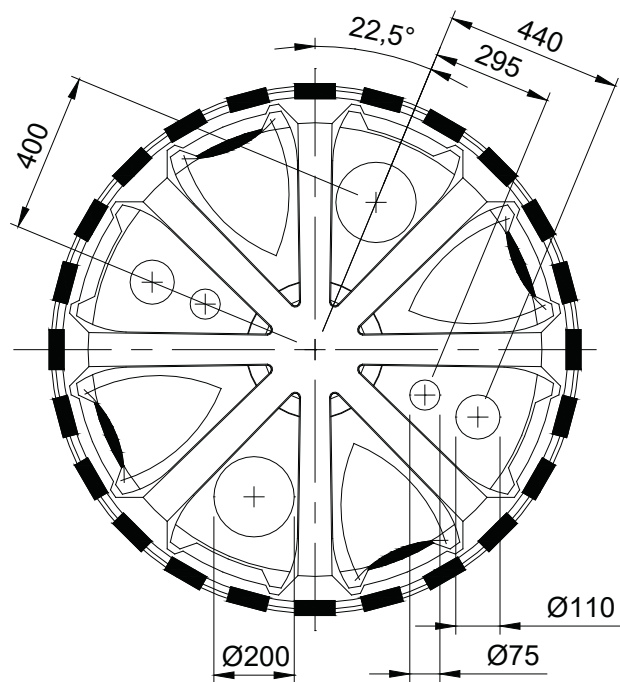
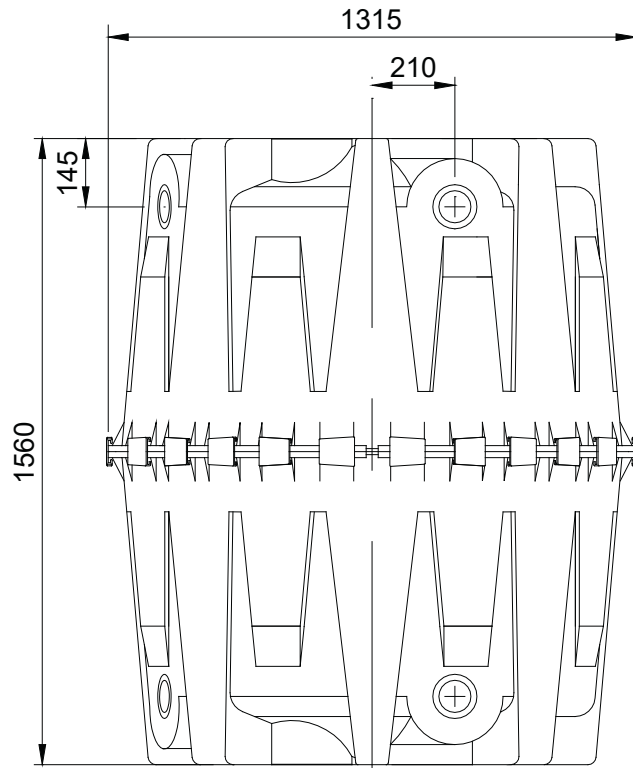

## 4. Transport and storage

### 4.1 Transport

Only companies having appropriate means of transport and correspondingly trained personnel may transport the tanks. During transport the tanks have to be secured against shifting and falling down. If the tanks are secured during transport by means of load straps, it has to be ensured that the tanks remain undamaged. Clamping or lifting the tanks using steel ropes or chains is inadmissible.

Strains caused by impacts have to be avoided in any case. The tanks must not be rolled or pulled over the ground in any case.

### 4.2 Storage

If the tanks have to be stored intermediately, they have to be stored on appropriate, level ground without sharp objects. During storage damages due to environmental effects or external effects have to be avoided. Unauthorised persons have to be kept away from the tanks.

## 5. Installation tank

### 5.1 Test installation

Before installing the tank finally it should be assembled tentatively in order to determine the following connections:

- Empty conduit connection
- Supply line
- Overflow line

After having opened the connections, all boring respectively sawing chips have to be removed from the tank.

### 5.2 Installation tank

The tank consists of two half shells that are identical in construction. In order to install the tank, one of the shells is put on level ground with the closed side pointing downwards. Afterwards, the profile gasket is pushed into the circumferential inner groove with the corrugated side astringent.

Before adding the second half shell, the gasket and the groove of the upper half shell have to be rubbed with the soft soap supplied in a slathering manner. When adding the second half shell (the half shells fit in one position only – observe arrow marking) it has to be paid attention to the gasket not slipping from the groove. If the tank is to be installed under ground, the **GRAF support tube** (Order No. 322014) has to be placed in the centre of the lower shell before adding the second half shell.

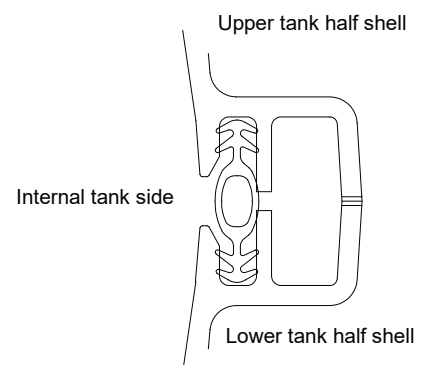

In order to connect the shells, the quick connectors are attached in an alternating manner to the left and to the right. For this, every second connector is pre-adjusted manually in the first step and afterwards attached using a hammer and a wooden support. In order to facilitate the installation, the connectors should be greased on the inner edges. The connectors engage in their final position.

Afterwards, all remaining connectors are attached as described.

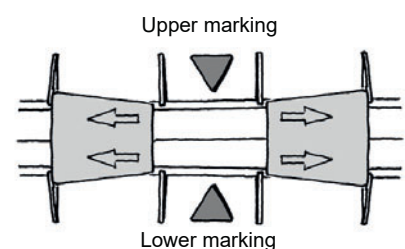

## 6. Overground and underground installation

### 6.1 Overground installation

When installing the tank above ground it has to be paid attention to the tank being emptied completely in case of risk of frost. Furthermore, the tank has to be installed on firm and level ground without sharp objects. The overall weight of the filled tank (1,650 kg) has to be observed when installing the tank. The tank should be installed in a shady environment. If the tank is installed in closed rooms, it has to be paid attention to a floor drain being designed. The tank must not be pressurised, i.e. the overflow installed (on the side of the tank) has to have the same diameter as the supply. It is imperative to provide sufficient ventilation.

### 6.2 Underground installation

#### 6.2.1 Construction site

Under all circumstances, the following points must be clarified prior to installation:

- The structural suitability of the ground according to DIN 18196
- Maximum groundwater levels which occur and drainage capability of the subsoil
- Types of load which occur, e.g. traffic loads

An expert ground report should be requested from the local planning authority to determine the physical characteristics of the subsoil.

#### 6.2.2 Trench

To ensure that sufficient space is available for working, the base area of the trench must exceed the dimensions of the tank by 500 mm on each side; the distance from solid constructions must be at least 500 mm.

The embankment must be designed according to DIN 4124. The construction site must be horizontal and plane and must guarantee sufficient load-bearing capacity.

The depth of the trench must be dimensioned so that the max. earth coverage (see point 2 - Installation conditions) above the tank is not exceeded. To use the system throughout the entire year, it is necessary to install the tank and those parts of the system which conduct water in the frost-free area. The frost-free depth is usually approx. 800 mm; precise information in this regard can be obtained from the responsible authority.

A layer of compacted, round-grain gravel (grain size 8/16, thickness approx. 150 - 200 mm) is applied as the foundation.

#### 6.2.3 Ground water and cohesive soils (impervious to water)

Installing the tanks in areas with ground water is admissible, if a sufficiently stable geogrid - to be provided by the customer - (tensile force at least 50 kN/m<sup>2</sup> in longitudinal and cross direction) with dimensions of 2.5 x 2.5 m is installed and anchored above the tank as safety measure against upwelling.

**Height of vertical cover in case of ground water and cohesionless soils (permeable to water) (installation with safety measure against upwelling):**

<b>Immersion depth of the tank into the ground water</b>	≤ 650 mm	800 mm	1000 mm	1200 mm	1600 mm
<b>Required height above ground</b>	≥ 400 mm	500 mm	700 mm	800 mm	900 mm

If there is the risk of exceeding the maximum admissible level of ground water, a sufficiently dimensioned drainage line has to be routed in any case.

**In case of cohesive soils (impervious to water), e.g. silt, a minimum height of the vertical cover of 900 mm incl. safety measure against upwelling and a sufficiently dimensioned drainage line are mandatory.**

## 6. Overground and underground installation

### 6.2.4 Slope, embankment, etc.

On installation of the tank in the immediate vicinity (< 5 m) of a slope, earthen mound or slope, a statically calculated supporting wall must be erected to absorb the soil pressure. The wall must exceed the dimensions of the tank by at least 500 mm in all directions, and must be located at least 500 mm away from the tank.

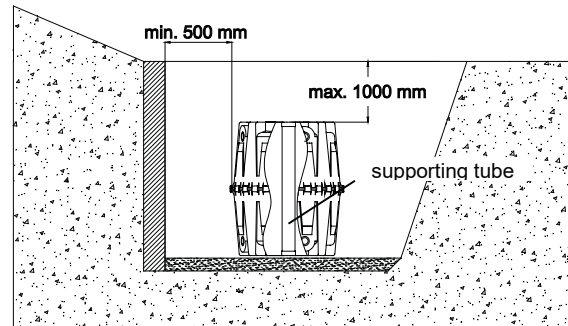

### 6.2.5 Installation next to accessible areas

When installing the tanks near accessible areas, it has to be provided that occurring strains by vehicles are not transferred to the tanks. The angle of the fictitious connection line between outer edge of the thoroughfare area and lower edge of the tank must be 45° at the most, i.e. the minimum distance to the accessible area is 2.6 m.

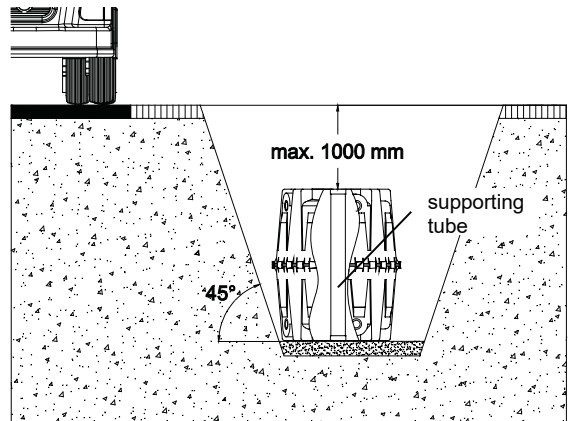

### 6.2.6 Connection several tanks

Two or more tanks are connected using the mounting areas situated on the bottom of the tanks via GRAF expansion kit (Order No. 322008) and plastic tubes used for underground installation (to be provided by the customer). The recesses have to be drilled using the GRAF special bit drill (Order No. 332001) in the corresponding size. It has to be paid attention to the distance between the tanks not falling below 800 mm. The plastic tubes used for underground installation have to extend into the tanks at least 200 mm. If two or more tanks are to be connected to one another then in addition to the lower connection (inlet) there must also be an upper connection to ensure ventilation.

### 6.2.7 Insertion and backfilling

The tanks have to be introduced into the prepared excavation pit without impacts using appropriate equipment (see also point 4 - Transport and storage)

In order to avoid deformations, the tank is filled with water up to 1/3 of its volume **before** starting to backfill the tank coating. Afterwards, the coating (rounded gravel max. granulation 8/16 according to DIN 4226-1) is backfilled and compressed layer-wise in steps of maximum 30 cm until reaching 1/3 of the height. Then, the tank is filled with water up to 2/3 of its volume and backfilled and compressed with layers of 30 cm again until reaching 2/3 of the height, etc. The individual layers have to be compressed properly (hand rammer). Damaging the tank during compacting is to be avoided. Mechanical compression machines must not be used in any case. The coating has to have a width of at least 500 mm.

## 6. Overground and underground installation

### 6.2.8 Routing the connections

All supply and overflow lines have to be routed with an incline of at least 1%. The lines are connected to pre-drilled recesses on the tank or to mould ports to be opened. If the tank overflow is connected to the public duct system, it has to be protected against backwater according to DIN 1986 for mixed ducts via a lifting system or when it is connected to a pure rain water duct via a backwater gate.

If the tanks are installed in a module system of more than 2 tanks, the supply line has to be installed on the first and last tank. In this case the withdrawal is implemented in the middle tank. The first and the last tank have to be equipped with an overflow as well.

All suction respectively pressure and control lines have to be routed through an empty conduit that has to be routed as straight as possible and with an incline, but without bending. Required bends have to be implemented with 30° moulded parts. The empty conduit has to be as short as possible.

**Important:** The empty conduit has to be connected to a recess **above** the max water level.

In order to create ventilation for the tank, a DN 110 plastic tube for underground installation has to be connected to the free recess and routed in an ascending manner (discharge end point Order No. 369017). Connection to ventilation systems of other buildings is inadmissible.

## 7. Installation tank head DN 200

The tank head has to be put on one of the moulded and opened ports DN 200 with sleeve. It can be shortened from above, but must not be extended in any case. The telescope 200 with removable cover forms the end with the surface (accessories, item number 322026).

Concrete shafts or similar must not be used by any means, but only the GRAF tank head DN 200.



## 8. Service and maintenance

The system as a whole has to be checked for leaks, cleanliness, and stability at least every three months.

The system as a whole should be maintained every 5 years. In doing so, all system components have to be cleaned and checked for functionality. Maintenance works should be conducted as follows:

- Empty tank completely
- Remove immovable residua using a pressure washer through the tank head
- Remove all contaminations from the tank
- Check all installation parts for proper seat