

TIPO TYPE		POTENZA NOMINALE NOMINAL POWER		POTENZA ASSORBITA INPUT POWER	AMPERE		Q = PORTATA - CAPACITY														
Monofase Single-phase	Trifase Three-phase	P2		P1	Monofase Single-phase	Trifase Three-phase	m³/h	0,6	1,2	1,8	2,7	3,6	4,8	5,4	6	7,2	9	9,6	12	13,2	
		HP	kW	kW			lt/1'	10	20	30	45	60	80	90	100	120	150	160	200	220	
Prevalenza manometrica totale in m.C.A. - Total head in meters w.c.																					
CAM 152	CA 152	1,5	1,1	1,5	7	3	H (m)	45	42	40	35	33	28	25	22	16	10				
CAM 202	CA 202	2	1,5	2	9	4,2		47	46	43	39	35	32	29	27	20	13				
CAM 302	CA 302	3	2,2	3	13,5	5,2		55	53	52	50	48	45	43	42	38	33	32	25	22	

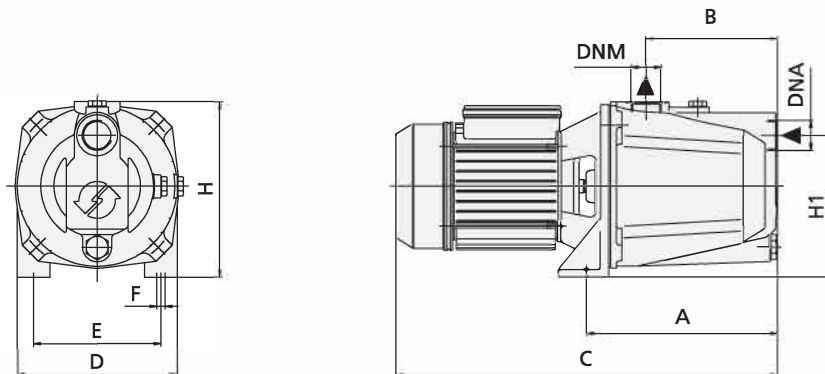

TIPO TYPE		DIMENSIONI mm - DIMENSIONS mm										DIMENSIONI DIMENSIONS mm			PESO WEIGHT
Monofase Single-phase	Trifase Three-phase	A	B	C	D	E	F	H	H1	DNA	DNM	P	L	H	Kg
CAM 152	CA 152	284	153	505	206	145	12	217	170	1" ¼	1"	234	550	285	27,6
CAM 202	CA 202	284	153	505	206	145	12	217	170	1" ¼	1"	234	550	285	27,6
CAM 302	CA 302	290	174	570	225	166	12	230	183	1" ½	1" ¼	245	600	300	31,5