

TIPO TYPE	POTENZA NOMINALE NOMINAL POWER		POTENZA ASSORBITA INPUT POWER	AMPERE	Pressostato pre-tarato Adjusted switch on/off pressure	Q = PORTATA - CAPACITY										
	P2	P1	Monofase Single-phase			Prevalenza manometrica totale in m.C.A. - Total head in meters w.c.										
Monofase Single-phase	HP	kW		kW	Monofase Single-phase	Bar	m³/h	0,6	0,9	1,2	1,5	1,8	2,1	2,4	2,7	3
	CAM 66/60	1	0,75	1			4,9	1,6 ÷ 3,2	H	46	43	40	37	35	33	30
CAM 100/60	1	0,75	1,1	5	1,6 ÷ 3,2	(m)	46	43	40	37	35	33	30	29	26	22

TIPO TYPE	POTENZA NOMINALE NOMINAL POWER		POTENZA ASSORBITA INPUT POWER	AMPERE	Pressostato pre-tarato Adjusted switch on/off pressure	Q = PORTATA - CAPACITY										
	P2	P1	Monofase Single-phase			Prevalenza manometrica totale in m.C.A. - Total head in meters w.c.										
Monofase Single-phase	HP	kW		kW	Monofase Single-phase	Bar	m³/h	0,6	1,2	1,8	2,7	3,6	4,8	5,4	6	7,2
	CAM 152/60	1,5	1,1	1,5			7	1,6 ÷ 3,2	H (m)	45	42	40	35	33	28	25

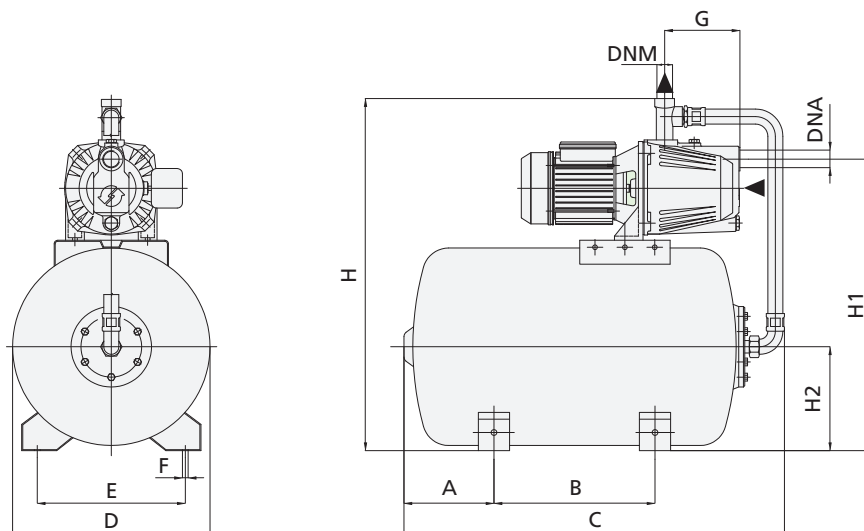

TIPO TYPE	DIMENSIONI mm - DIMENSIONS mm												DIMENSIONI DIMENSIONS mm	PESO WEIGHT		
	A	B	C	D	E	F	G	H	H1	H2	DNA	DNM				
Monofase Single-phase													P	L	H	Kg
CAM 66/60	173	295	748	380	305	11	90	670	545	215	1"	1"	400	775	730	30,5
CAM 100/60	173	295	748	380	305	11	145	670	551	215	1"	1"	400	775	730	31,5
CAM 152/60	173	295	748	380	305	11	171	698	603	215	1" ¼	1"	400	775	730	43,6