

No rights can be derived from these drawings. The sizes may differ in reality.

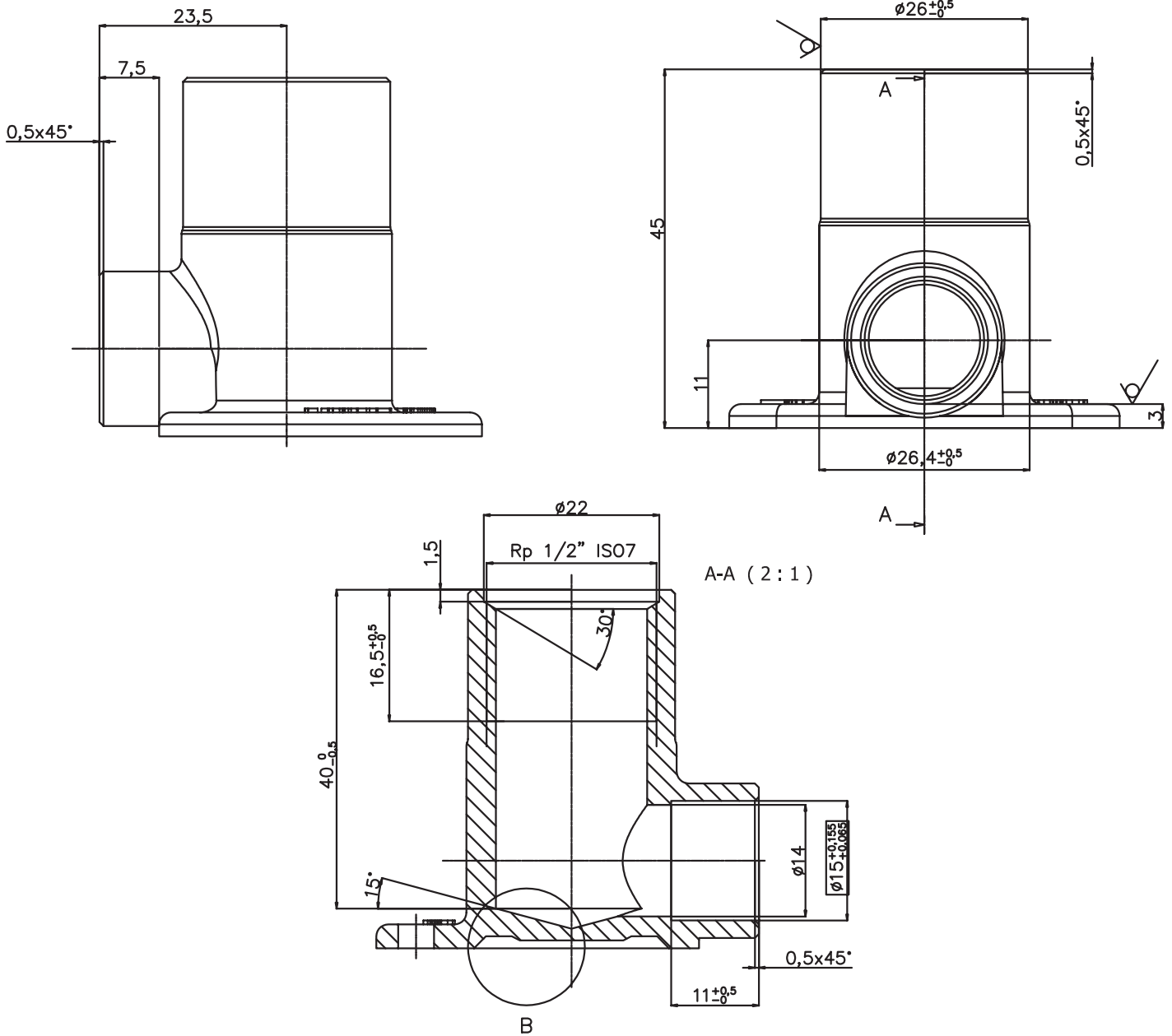

DESCRIZIONE DESCRIPTION		Murplaat hoog 1/2" binnen x 15 mm - flangia a muro alta		REV.	
CODICE GRUPPO ASSEMBLED PART NR.		MATERIALE MATERIAL		SCALA SCALE	2 : 1
TRATTAMENTI TREATMENTS		GENERAL TOLERANCES $\pm 0,2$ NOT SPECIFIED RADIUS R=1 SHARP EDGES WITHOUT BURRS SM 0.2X45°		PESO STAMPATO GRO. W.	PESO FINITO NET W.
NOTE REMARKS		<input type="checkbox"/> CARATTERISTICA IMPORTANTE KEY FEATURE			Gr. 137

No rights can be derived from these drawings. The sizes may differ in reality.

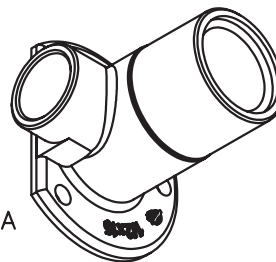
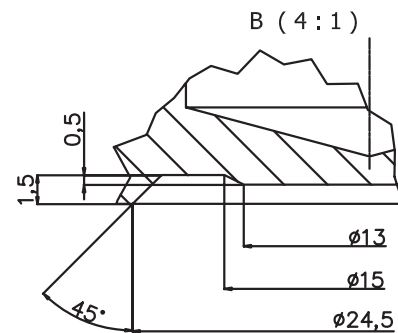
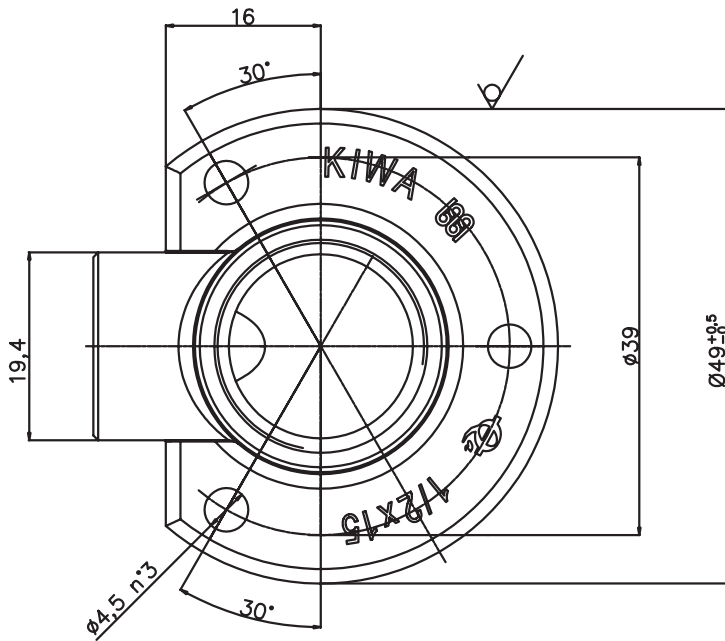

VISTA ASSONOMETRICA  
SCALA 1:1

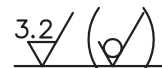

DESCRIZIONE DESCRIPTION		Murplaat hoog 1/2" binnen x 15 mm – flangia a muro alta		REV.	
CODICE GRUPPO ASSEMBLED PART NR.		MATERIALE MATERIAL		SCALA SCALE	2 : 1
TRATTAMENTI TREATMENTS		GENERAL TOLERANCES ±0.2 NOT SPECIFIED RADIUS R=1 SHARP EDGES WITHOUT BURRS SM 0.2X45°		PESO STAMPATO GRO. W.	PESO FINITO NET W.
NOTE REMARKS		<input type="checkbox"/> CARATTERISTICA IMPORTANTE KEY FEATURE			Gr. 137